



Tra le briccole di Venezia

RIVA



Tra le briccole di Venezia





Il legno riposa,
ma non dorme.
Ci anticipa nei pensieri
e si prepara a ciò
per cui non esistono
ancora le parole

Wood rests,
but never sleeps.
It thinks faster than us,
and it prepares us
for something for which
there are as yet no words

Davide Riva

Tra le bricole di Venezia

Una nuova Collezione che coinvolge 34 grandi nomi del design, dell'arte e della moda che si carica di valori ecologici legati al riuso di un manufatto che è parte del paesaggio veneziano: le Briccole, pali in legno di rovere che spuntano dalla laguna. Corrosi dalle maree, sono interpretati da famosi designer e trasformati in oggetti d'arte da Riva 1920.

Among the posts in Venice.

A new Collection involving 34 big names from the design, art and fashion world, supporting ecologic values linked to the re-use of a peculiar product belonging to the Venetian landscape: the "Briccole", posts made of chestnut oak arising from the lagoon. Corroded by tides, they are re-interpreted by famous designers and turned into artworks by Riva 1920.



Progetti di
Projects by

- 4 Terry Dwan
- 6 Paola Navone
- 8 Angela Missoni
- 10 Luisa Castiglioni
- 12 Antonio Citterio
- 14 Matteo Thun
- 16 Michele De Lucchi
- 18 Mario Botta
- 20 Riccardo Arbizzone
- 22 Elio Fiorucci
- 24 Paolo Pininfarina
- 26 Franco Orioni e Matteo Orioni
- 28 Pierluigi Cerri
- 30 Erasmo Fignini
- 32 Enzo Mari
- 34 Marc Sadler
- 36 Luca Scacchetti
- 38 Aldo Cibic
- 40 Helidon Xhixha
- 42 Karim Rashid
- 44 David Chipperfield
- 46 Aldo Spinelli
- 48 Carlo Colombo
- 50 Paolo Piva
- 52 Claudio Bellini
- 54 Thomas Herzog
- 56 Philippe Starck
- 58 Pinuccio Sciola
- 60 Alessandro Mendini
- 62 Andrea Branzi
- 64 Giuliano Cappelletti
- 66 Piero Lissoni
- 68 Gualtiero Marchesi
- 70 Davide Riva e Maurizio Riva

La storia delle briccole

Protagoniste indiscusse della città di Venezia, le Briccole, i pali da sempre presenti nella laguna, guidano le imbarcazioni e segnalano la bassa marea. Periodicamente vengono sostituite dopo essere state scolpite da "piccoli artisti", i molluschi, che attraverso un lavoro fatto di buchi dalle forme tonde assolutamente perfette lasciano il segno del loro passaggio. Un palo infisso in laguna dura in media 5 -10 anni, poi, corroso in corrispondenza dell'escursione di marea nel quale trovano il loro habitat naturale flora e fauna marina, viene sostituito.

La nostra attenzione all'ecologia e all'ambiente ci ha ispirato a dar nuova "vita" a questo legno. Riutilizzare le briccole, in modo tale che possano diventare un oggetto senza alcuna necessità di imitazione né di citazione lagunare, non è un'operazione semplice, in quanto la memoria, il capitale simbolico sono talmente forti che potrebbero condizionare qualsiasi tipo di riprogettazione.

La presentazione di questo grande progetto, si avvale dell'importante e assoluto impegno di 33 designer, stilisti e scultori contemporanei, che con il loro lavoro hanno voluto dare un tributo alla città di Venezia. Nel realizzare giorno dopo giorno questi fantastici progetti abbiamo sempre e comunque pensato che tutto questo debba restare in memoria per Venezia e per coloro che dopo di noi ne saranno attratti...rispettando il dolce sapore della vita.

Maurizio e Davide Riva

Unquestioned protagonists of the city of Venice, the Briccole, the posts standing in the lagoon from time immemorial, guide boats and alert as tides rise and fall. They are periodically replaced after being carved by "little artists", the molluscs, which have left, through a meticulous work of perfectly-round shaped holes, sign of their passage. A post sunk into the lagoon lasts approximately 5-10 years after which, the water-beaten area of the posts, which is also the one mostly affected by tides rise and fall and by the presence of micro-organisms, is deemed damaged, and the briccola is replaced. Our concern with ecology and the environment inspired us to give this wood a new "life". Re-using the briccole in such a way as to transform them into an object with no need to imitate or make direct references to the lagoon is not easy, since our memories of them, our symbolic capital, are so strong that they unduly threaten to influence any attempt at re-designing. The achievement of this important project benefits from the generous and committed support of 33 contemporary designers, stylists and sculptors, eager to pay homage to the city of Venice. Working every day on these fantastic projects we have often thought that all this must act as a permanent tribute to Venice and should remain in the memories of all those future generations that will be attracted by it...with respect for the sweetness of life.

Maurizio e Davide Riva



Codice: Briccole

La consolle "Codice: Briccole" è un'interpretazione di ciò che rappresentano le briccole recuperate dalla laguna di Venezia. Il "Codice: Briccole" raffigura i cinque elementi di Aristotele. L'acqua, l'aria e il fuoco sono gli elementi che hanno lasciato il loro segno sulla superficie dei tronchi, la terra e l'etere sono gli elementi che li hanno prodotti. Il progetto è un DNA o una codificazione della bricola nel contesto paesaggistico di Venezia.

The "Briccole code" console is an interpretation of what the briccole recovered from the Venice lagoon represent. The "Briccole code" portrays Aristotle's five elements. Fire, air and water are the elements that have left their own mark on the outside of the tree trunks; earth and ether are the elements that produced them. The project is a DNA or a codification of the bricola in the context of the Venetian landscape.



Terry Dwan





Paola Navone



Briciole

Alberi consumati dal tempo e dall'acqua.
Architettura tra cielo e mare. Sculture di bellezza imperfetta. Ho cercato di immaginare quanti ricordi, pensieri, fantasie e sogni sono passati accanto a loro nel tempo. Sono i piccoli oggetti che ho nascosto nel legno. Con un gesto che non si sovrappone e non cancella, ma accosta e intreccia all'essenza delle briciole tante altre storie.

Trees ravaged by time and water.
An architecture placed between the sky and the sea.
Sculptures of an imperfect beauty. I tried to imagine how many memories, thoughts, fantasies and dreams have drifted past them in their time.
These are the little objects I have concealed in the wood. It is a gesture who neither superimposes the new nor cancels the old: it simply adds other lives and interweaves them with the essence of the briciole.





Miss Amaca

Briccole come supporto di amache.
Le ho immediatamente viste così, come strutture portanti per la più primordiale, essenziale e perfetta delle chaise longue mai inventate.
Briccole che, sparse qua e là, al largo della laguna, sostengono una serie di accoglienti, avvolgenti, protettivi cocoon in spessa chiara rete di juta, di nylon o di cotone.

Briccole as supports for hammocks.
I immediately figured them out this way, as supporting structures for the most primordial, essential and yet perfect of all chaise longues ever invented. Briccole that dotted here and there around the lagoon, support a series of cosy, welcoming, protective cocoons made of a thick, brightly coloured net of jute, nylon or cotton.



Angela Missoni

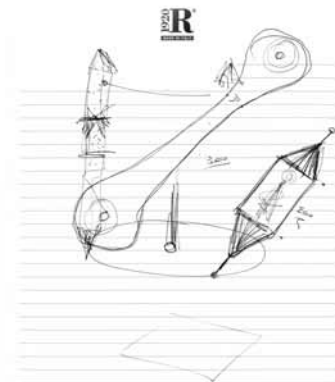

Briccole a Murano

Le briccole appartengono all'immagine di Venezia come l'acqua della laguna. Infatti spuntano dall'acqua dei canali qui tre strani pali bianchi di legno, inclinati uno sull'altro, da quasi cinquecento anni per segnalare ai veneziani il percorso navigabile. La loro funzione è insostituibile. Il tema del "riuso" della Briccola proposta dai fratelli Riva ai così detti "designer" è certamente interessante e intrigante. Faccio anch'io una modesta proposta di una briccola con del vetro colorato.

The briccole are as much a part of our image of Venice as the water of the lagoon. Indeed, here three strange white wooden posts protrude from the water, leaning one against the other as they have done for nearly five hundred years, to alert Venetians where their boats can safely travel. Their function is essential. The theme of the re-use of the briccola suggested by the Riva brothers to the designers is certainly a fascinating one. I would like to make a modest proposal for a briccola with coloured glass.

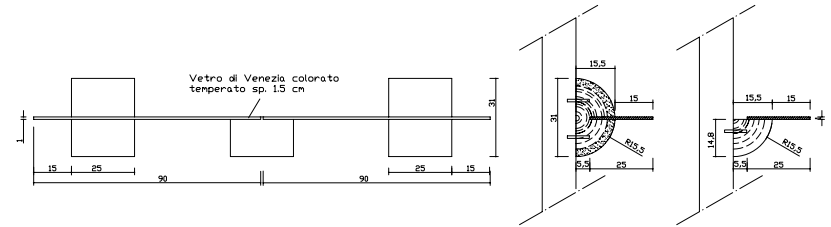

Luisa Castiglioni

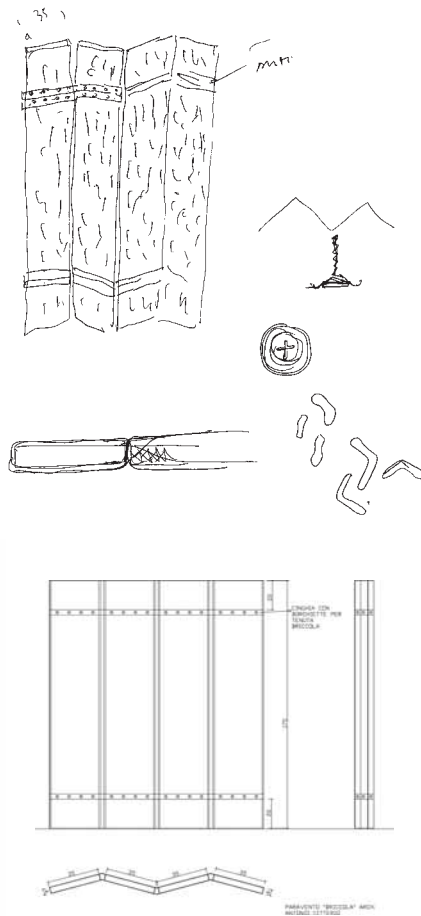

Antonio Citterio

Ho trovato particolarmente interessante collaborare al progetto proposto da Riva 1920, sia in termini di riutilizzo di un materiale ricco di storia e bagaglio culturale come la briccola di Venezia, sia in termini di ridisegno di un oggetto. Forse la parte che ha più memoria di queste Briccole è quella esterna, quella più segnata dal tempo e dalla natura.

I was particularly keen to participate in the project proposed by Riva 1920, both because it aims to re-use a historically and culturally rich material like the Venetian briccola and because it aims to design a new object. Perhaps the part of these briccole that is most evocative is that most ravaged by time and nature.



Briccole Venezia

“Ispirato dal Canale Grande e le fermate dei gondolieri è nato un tavolo fatto dal legno con le briccole tipiche di Venezia. Ogni tavolo è unico - un pezzo di Venezia a casa.”

Il top è realizzato con tavole uniche sezionate dalle “briccole”, mantenendo la forma originale del tronco. Le gambe oblique si incastrano al top richiamando il tipico paesaggio lagunare veneziano.

“The wood for this table comes from Venice’s briccole, poles that mark the gondola stops along its canals. They are our inspiration. Here each table is unique – a piece of Venice in your home”.
The tabletop is made of planks, each different from the other, cut from these briccole and keeping their original shape. The angled legs fit into the top, a reminder of the unique seascape of the Venetian lagoon.



Matteo Thun

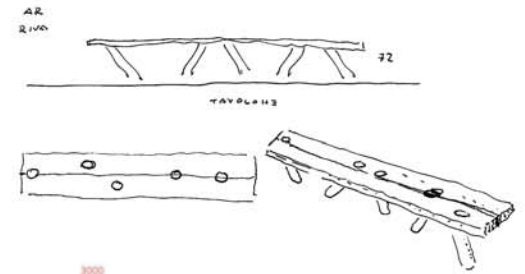

Il Briccolone

Che straordinaria idea è stata quella di andare a recuperare le briccole di Venezia! Il Briccolone è una grande briccola fatta con il legno originale delle "briccole" e che ha funzione di una libreria: mette in evidenza la bellezza del materiale corroso dai molluschi, dall'acqua, da sale, dal tempo, dai gondolieri, dai turisti, dai topi, dai colombi e da tutti i normali frequentatori di Venezia e mantiene il suo cuore puro, sano, generoso, incorruttibile e ben visibile sotto la crosta.

What an extraordinary idea to recover the briccole of Venice! The Briccolone is a big briccola realized using the original wood of marker posts and making out of it a book case. It shows off the beauty of the material, eroded by molluscs, by the water, by salt, by time, by the gondoliers, the tourists, the rats, the pigeons and by all other normal city passers-by, maintaining nonetheless its heart pure, healthy, generous, incorruptible and clearly visible beneath its outer crust.

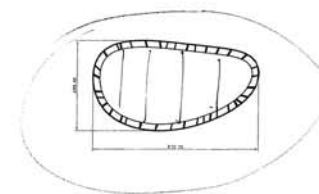
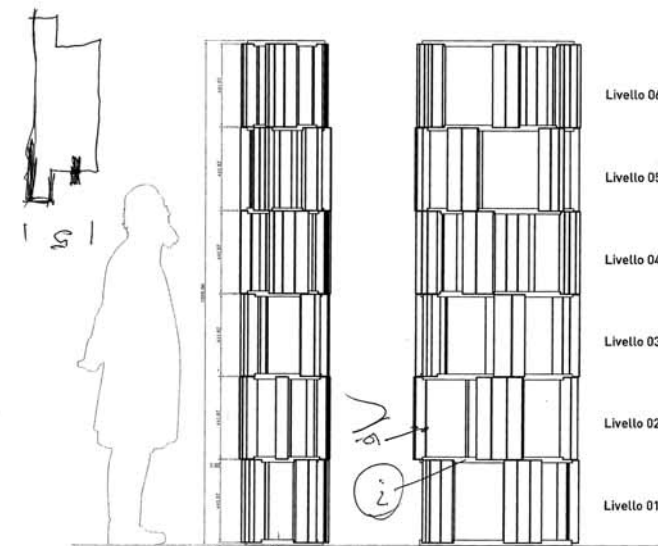

Michele De Lucchi

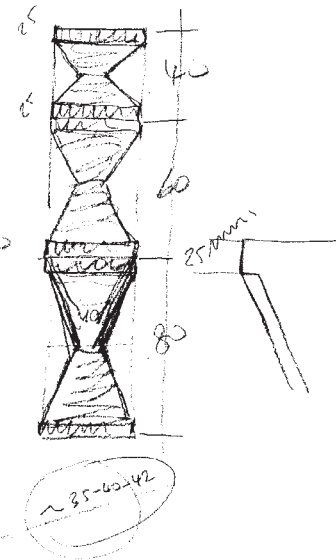
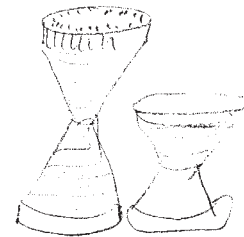
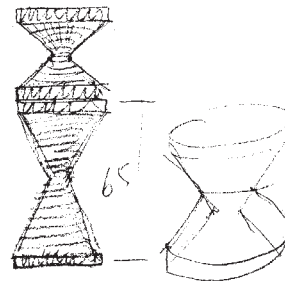

Bricolages

"Bricolages": omaggio a Brancusi.
Sedute - sgabelli - tavolini.
Le bricole di Venezia hanno cento vite;
basta scavare oltre la corteccia
per ritrovarne l'anima.

"Bricolages": a homage to Brancusi.
Seats - stools - small tables
The bricole of Venice have 100 lives;
just dig beneath their bark and
you'll find its soul.



Mario Botta



Riccardo Arbizioni

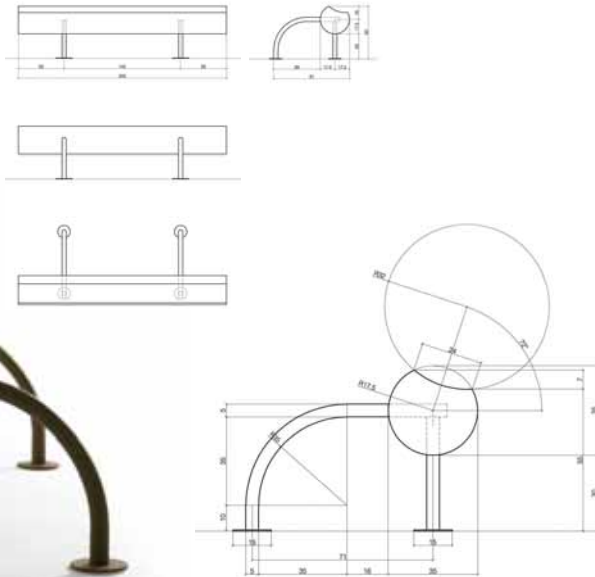

Divan: punto d'incontro

Per lunghi secoli la città di Venezia è stata una porta sull'Oriente, con cui ha intessuto un dialogo fitto e continuo, contrassegnato da rapporti culturali e commerciali che rifulgono ancora nel ricordo di Marco Polo. Per il nostro progetto ci siamo ispirati al concetto di punto d'incontro, di seduta in un ambito peculiare, che è quello dell'influsso delle tradizioni orientali: il recupero medesimo del concetto di divano come punto d'incontro: parola che designava nel mar del Levante anche la dogana: che altro non è se non l'aspetto meno piacevole del rapporto tra culture, etnie, nazioni diverse.

For many centuries the city of Venice was a gateway to the Orient, with which it had woven a dense and continuous fabric of dialogue highlighted by cultural and commercial contacts which still radiate in the diaries of Marco Polo. Our project is inspired by the concept of the meeting point, a seat in a special setting, the entry point of oriental traditions. We relate the concept of the divan as a meeting point with its other meaning in the Eastern Mediterranean of customs house, which is nothing other than the less pleasant aspect of the contact between different cultures, ethnic groups and nations.



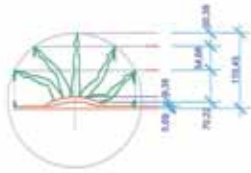
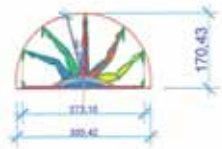
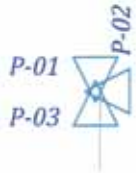

Venetian Mermaids

Tutto, a Venezia, emerge dall'acqua! I palazzi, le chiese, i ponti e le Briccole... Le briccole diventano gambe di ragazze che nuotano ed escono dalla linea dell'acqua della laguna. L'emergere dal livello fermo dell'acqua rappresenta il movimento che esce dalla profonda cultura di una delle città più belle del mondo e rappresenta la luce di Venezia.

Everything in Venice emerges from the water! Buildings, churches, bridges and the briccole... The Briccole here become the legs of swimming girls, breaking the surface of the lagoon. This sense of emerging out of the water reflects the continuous motion stemming out of the deep culture of one of the world's most beautiful cities, and represents the light of Venice.



Elio Fiorucci

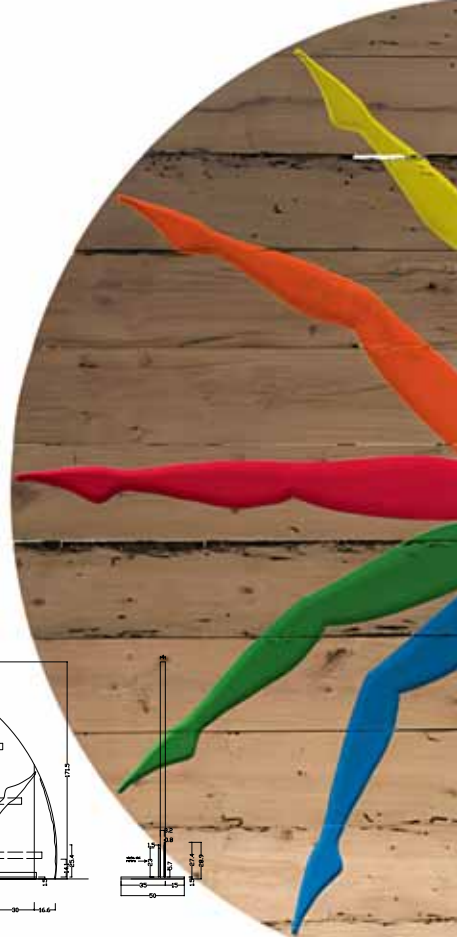
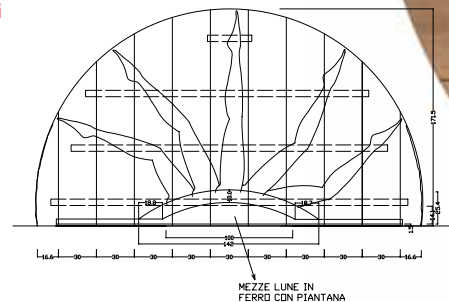

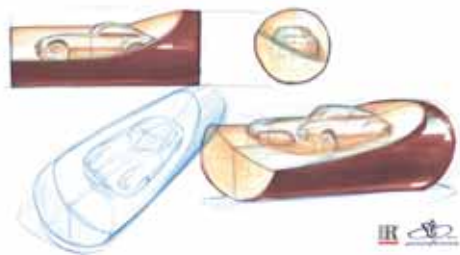

Cisitalia 202

Le linee sinuose della Cisitalia 202 del 1947 sono state scolpite nel legno dando vita ad un'opera d'arte apparentemente modellata dalla natura, così come il tempo e il mare hanno lavorato i pali ai quali per decenni si sono ormeggiati i gondolieri veneti. La scelta della Cisitalia nasce dalla volontà di replicare con una scultura in legno le forme di un'auto da sogno, di una bellezza senza tempo, a sua volta definita "scultura in movimento".

The flowing lines of the 1947 Cisitalia 202 have been cut into the wood to create a work of art apparently modelled on nature, just as time and tide have left their marks on these poles where for decades the Venetian gondoliers moored their boats. We chose the Cisitalia because we wanted to replicate in the form of wooden sculpture the shape of a dream-car, of a timeless beauty, described in its time as a "sculpture in motion".

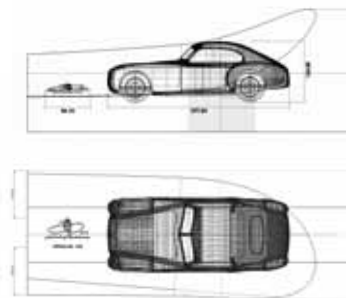

Paolo Pininfarina

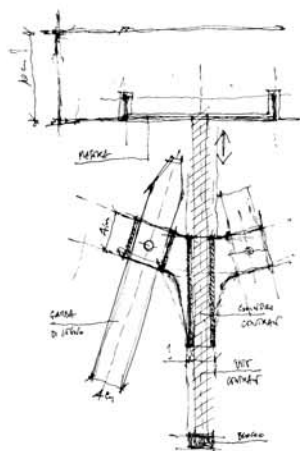
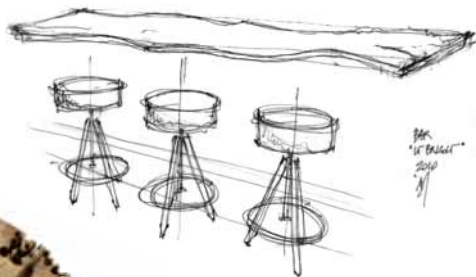

Brichello

Fin dal 1400 la laguna veneziana è disseminata di grossi pali che, emergendo dall'acqua a gruppi di tre, indicano la parte navigabile dei canali anche in condizione di bassa marea. Questo strano trepiede che pare camminare sulle acque marca dunque un limite, segnala un percorso oltre il quale è consigliabile non andare...

Since 1400 the lagoon of Venice has been dotted with big posts rising from the water in groups of three to mark the sections of the canals that are navigable even when the tide is low. This strange tripod that seems to walk on the water, marks a limit, indicates a line to follow beyond which it is inadvisable to venture...



Franco Origoni e Matteo Origoni



Oak

Mi piace e mi sorprende questa ostinata e benemerita attitudine di Riva a decontestualizzare i materiali, a proporli per un nuovo uso. Oak è un tavolo pensato come sintesi degli elementi costruttivi di un'architettura, ne mostra il pensiero e si concretizza in quattro pilastri a geometria variabile che sostengono un piano di ferro trattato nel colore della grafite.

I was delighted and surprised by Riva's stubborn and yet meritorious attitude to decontextualise materials, to suggest a new use for them. Oak is a table conceived as a synthesis of the constructive elements of an architecture, displaying the idea and concretely materializing in four columns of variable shapes in support of a rust-coloured iron top.



Pierluigi Cerri

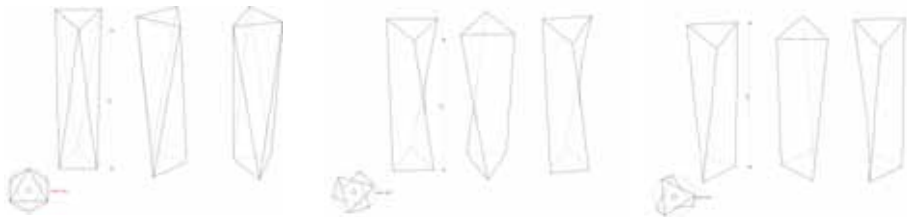



Erasmo Figini

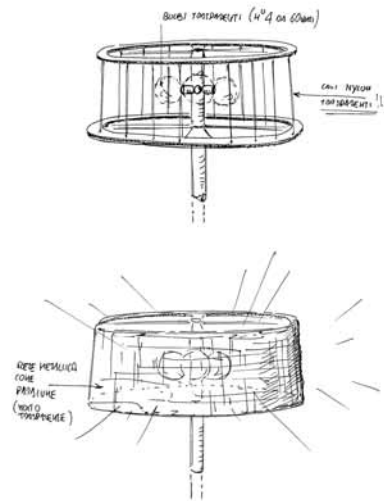
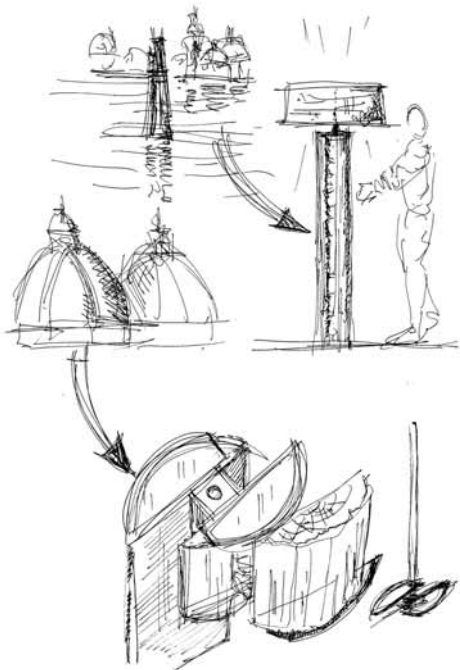

Serena

Questo oggetto di design nasce dal mio rapporto emotivo, direi quasi affettivo con la città di Venezia e trae ispirazione da alcuni degli elementi che caratterizzano questa straordinaria realtà: il legno, l'acqua, i riflessi dell'oro fissati nel vetro.

This design object is born out of my emotional relationship, indeed, my affective relationship, with the city of Venice. It draws inspiration from some of the elements that characterise this extraordinary reality: wood, water and the sparkle of gold fixed in glass.

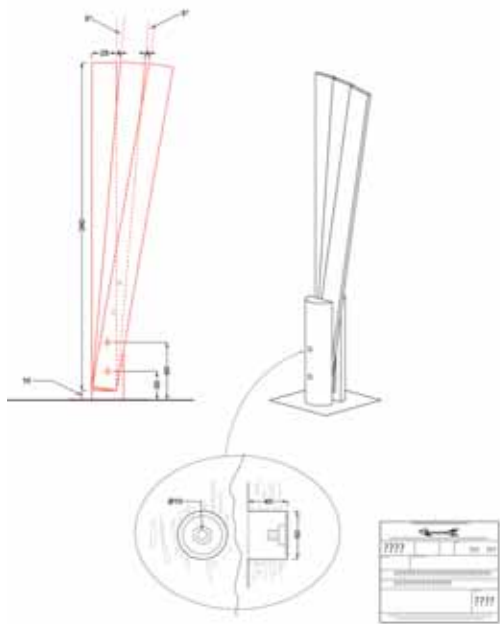

Stendardo

Maurizio e Davide Riva mi hanno chiesto di realizzare un progetto utilizzando il legno di quercia delle "Briccole" in disuso, destinate ad incrementare qualcuna delle infinite discariche. Chiunque inorridisce alla vista delle discariche. Cosa posso fare? Decido di realizzare un'opera quale stendardo per la mostra; da una Briccola non ripulita fuoriescono tre tavole di quercia semilavorate in attesa di essere utilizzate...

Maurizio and Davide Riva asked me to create a design using the oak wood from briccole, removed and doomed to increase the pile of waste of one of the countless dumping grounds. Anyone horrifies in front of a dumping ground. What are the choices before me? My idea is to create a standard for the exhibition: a base made of an uncleaned briccola supports a fan of three boards of semi-finished oak waiting to be used...

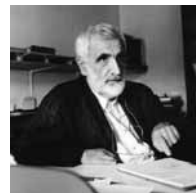

Enzo Mari



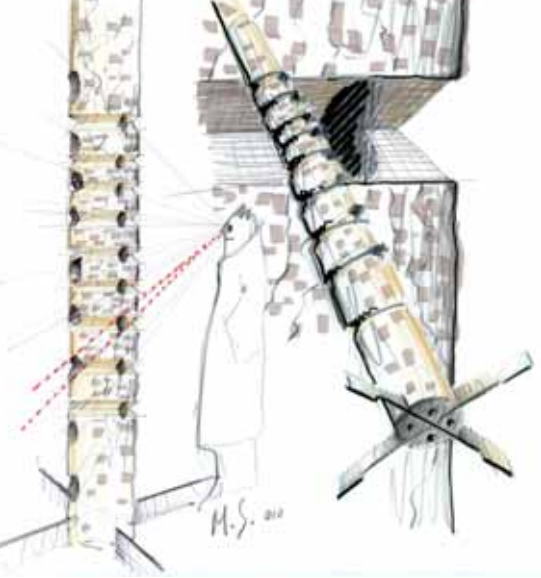

L'emblema di un periodo magico della mia vita: Venezia, una città dove ho scelto di vivere ad un certo punto della vita, lo spartiacque fra un prima e un dopo. E le bricole, baluardi di quella terra di frontiera non solo emozionale, ritte in mezzo alla laguna ad indicare la giusta via.

Venice, emblem of a magic period in my life, the city where I chose to live at a certain point, a watershed between what went before and what came after. And the bricole, bulwarks marking the edge of terra ferma – not only in emotional terms – rise like ritual objects in the midst of the lagoon to indicate where and where not to go.

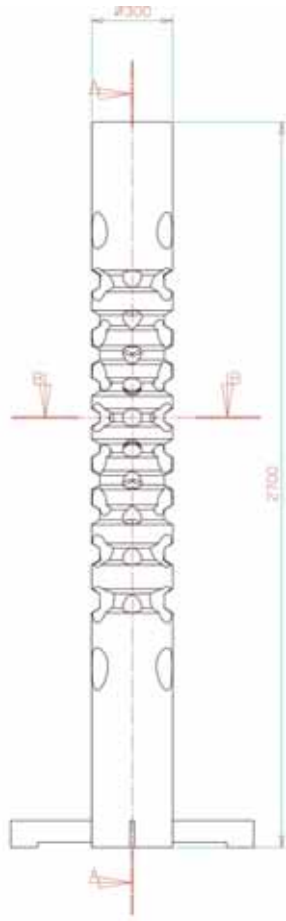

Marc Sadler





Luca Scacchetti

Cornice

Questo progetto offre l'opportunità di fermarsi a ragionare, anzitutto per la materia a disposizione. Materia che è già progetto, che è già racconto. La geometria elementare, euclidea, di telai e pannelli guida tutto il progetto. Quasi che il tavolo prima che tavolo fosse quadreria o macchina teatrale, scenografia esibita. Una struttura metallica dal colore bronzo incornicia la briccola, trasformata in asse lungo e immobile, in pannello sospeso, esposto come "legno" ritrovato, quasi archeologico a rappresentare una storia, un passato, non completamente conoscibile e misterioso.

This project offers an opportunity to stop and think, above all about the material provided. This material that is already a project, already a narrative. The elemental Euclidean geometry of sheets and panels determines the whole design. It is almost as if before being a table the table were picture gallery or theatrical machinery, a piece of scenery on show. A bronze coloured metal structure frames the briccola here transformed into long, fixed planks, suspended, exhibited like newly discovered "wood", almost archeological, to represent a story, a history that is mysterious and not completely knowable.



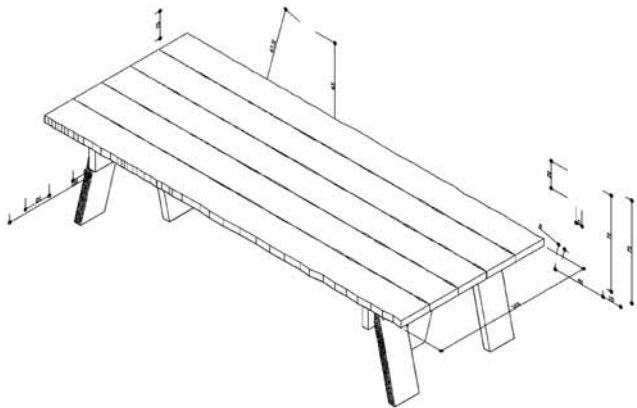

Aldo Cibic



Frammenti di wabi-sabi

In questo piccolo e molto interessante libro, scritto da Leonard Koren e intitolato Wabi-Sabi per artisti, designer, poeti e filosofi, si descrive il wabi-sabi come un "ideale artistico tipicamente giapponese che descrive la bellezza di oggetti di fattura rustica e non rifinita, solitamente caratterizzati da un uso di materiali naturali grezzi, da superfici ruvide o corrose dalle intemperie, da assenza di forme geometriche regolari e dai colori scuri o neutri". Quando ho visto per la prima volta le Briccole, con tutto il loro spessore esterno consumato dal tempo e dall'acqua, con quello strano effetto spugnoso, bucherellato, ho pensato che rappresentano proprio un'espressione dell'estetica del wabi-sabi.

In his small and fascinating book entitled Wabi-Sabi for artists, designers, poets and philosophy, Leonard Koren describes wabi-sabi as "a typically Japanese artistic ideal referring to the beauty of rustic, roughly finished objects, usually characterised by the use of natural, unrefined materials, worn or weathered surfaces, by the absence of geometrically regular forms and by dark or neutral colours". When I first saw the briccole- their great girths worn away by time and water and riddled with holes like a strange sponge - I thought they represented a perfect expression of the wabi-sabi aesthetic.

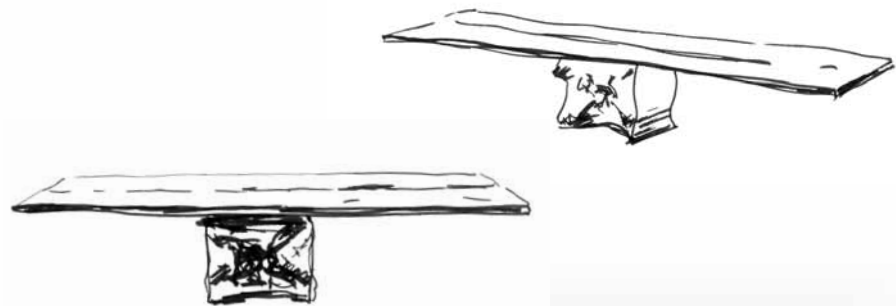

Helidon Xhixha

Riflessi in laguna

La creazione di quest'opera è frutto dell'unione delle "Briccole", le quali hanno sorretto nei secoli la città di Venezia impregnandosi dei segni della sua storia, e l'acciaio che attraverso i suoi riflessi, rappresenta l'acqua della Laguna anch'essa testimone nel tempo della vita passata accompagnando i movimenti di navi, uomini e cultura.

This work is the result of a fusion between, on the one hand, the briccole, for centuries the supporting structures of the city of Venice, weathered and scored by its history, and, on the other hand, steel whose sheen represents the gleam of the waters of the Lagoon, a witness to the passage and rhythm of life with its ships, its people and its culture.

ACCIAIO INOX SPECCHIO



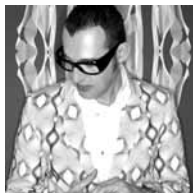

Karim Rashid

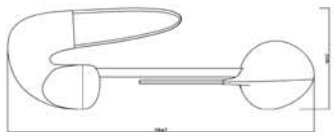

Forkola

Quando Riva 1920 mi ha contattato per propormi il progetto "Briccole" ho cominciato subito a ripensare ai giorni passati in Italia impegnato negli studi e all'importanza del cambiamento, abbracciando il futuro ma servendosi del passato per il valore che merita. Ho così pensato alle forme derivanti dal linguaggio delle gondole, forme organiche morbide ed allungate in contrasto con una trave geometrica puntellata.



When Riva 1920 approached me about Project Venice I immediately began thinking back to my days of studying in Italy and my time in Venice and also thinking of the importance of change while embracing the future and exploiting the past and its materials for all that it's worth. I then thought of the shapes derived from the language of gondolas, soft organic forms stretched into points connected by the contrasting geometric severity of connecting beams.



Bookshelf

Nella realizzazione fisica di un prodotto di design la sfida è quella di dare valore al materiale come alla forma.

Maggiore è la bellezza del materiale nella sua condizione naturale, maggiore è la difficoltà a conservare questa qualità attraverso il processo formale e tecnico.

The challenge in all physical realization of design is to give status to material as well as to form.

The more beautiful the material is in its natural form, the more difficult is to maintain this quality through the formal and technical process.

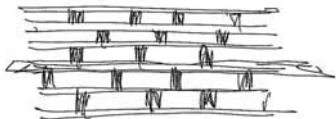

David Chipperfield



The challenge in all physical realization of design is to give status to material as well as to form. The more beautiful the material is in its natural form, the more difficult it is to maintain this quality through the formal and technical process.



Calle

L'amicizia che mi lega a Maurizio e Davide Riva così come la passione per il legno e l'innegabile fascino di Venezia mi hanno spinto con entusiasmo ad accettare questa sfida. Il progetto che ho sviluppato insieme al nostro Centro Ricerche è quello di un tavolo con top costituito da Briccole e da struttura in acciaio. Il legno indistruttibile delle Briccole forgiato dalle acque ed intriso di misteri legati alla sua vita precedente diventa così protagonista della nostra proposta di sofisticata essenzialità in grado di valorizzare le valenze tattili delle finiture.



Aldo Spinelli

The friendship that ties me to Maurizio and Davide Riva, together with my passion for wood and the undeniable charme of Venice, led me to enthusiastically accept this challenge.

The project I developed in association with the Riva 1920 Research Centre consists of a table with a steel structure and a top made of sawn "bricole". The indestructible wood of the "bricole" tempered by the waters and permeated with the mysteries of its previous life is at the centre of our design - one whose pared-down elegance is capable of giving best effect to the finished product's textures.

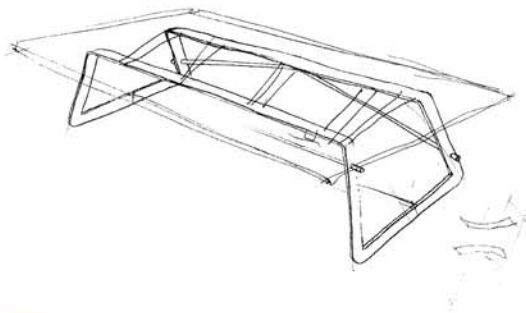

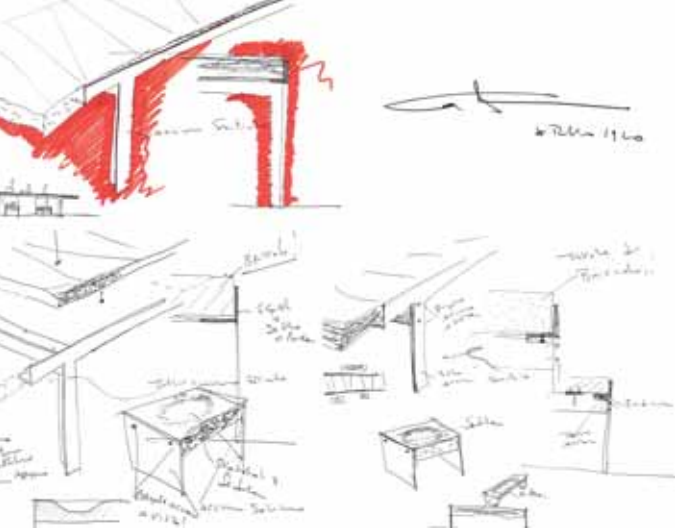

Touch

I prodotti progettati per "Le Briccole di Venezia" traggono ispirazione dalla volontà di coniugare elementi tecnici costituiti da un materiale tecnico e freddo come l'acciaio ed elementi caldi e morbidi come le tavole di legno derivanti dalle briccole. La struttura in acciaio, con viti a brugola a vista, creano una sorta di contenimento di sede e alloggio per l'elemento naturale, costituito dal legno del piano del tavolo sezionato con tavole di forma irregolare e dalle sedute delle sedie, lavorate con cavità superiore.

The products designed for "Le Briccole di Venezia" are inspired by the urge to conjoin materials that are cold and of a technical character like steel with materials evoking a warm tactility like the wooden boards made from the "briccole". The steel structure with its allen screws showing creates a sort of frame, a housing for the natural element, the wooden table top made from irregularly shaped boards and the chair seats made with the hollow facing upwards.



Carlo Colombo



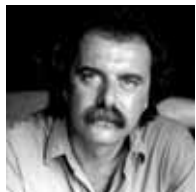
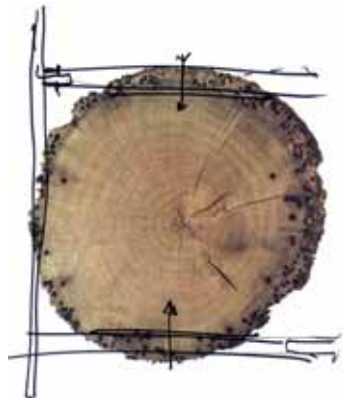
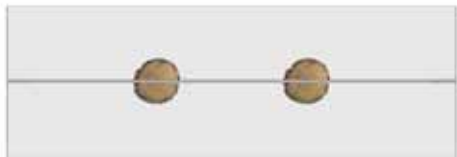

Paolo Piva



Laguna

Laguna è il nome del mio progetto per l'iniziativa Riva1920 che intende recuperare la poesia di queste "Briccole" ricollocandole nel loro ambiente naturale. Un progetto dedicato a Venezia e alla sua Laguna che cerca di isolare nel vetro questa presenza "silenziosa", celebrandone l'effimera e "antica" realtà.

I have called my project for the Riva 1920 initiative Laguna. The idea of this initiative is to preserve the poetry of these "bricole" repositioning them in their natural environment. My project is dedicated to Venice and to its lagoon; it seeks to encapsulate this silent presence in glass, celebrating its ephemeral yet ancient reality.





Claudio Bellini



Venice

Ed ecco ritornare le nostre amate Briccole... Dall'incanto surreale della laguna di Venezia, una magica metamorfosi ne restituisce l'anima, spoglia della fatica del tempo. Ravvicinate e statuarie in una ritmica composizione estendono il loro muto riflesso in un lucido mare d'acciaio, senza tempo.

And once again we are back with our beloved "briccole"... Rising out of the surreal enchantment of the Lagoon of Venice, a magical metamorphosis restores its soul, free from time's endless effort. Drawn together and united in rhythmic composition, their silent reflection extends across a shining sea of steel; timelessly.

Vice Versa

La nuova vita delle briccole. Erano sotto l'acqua e si ritrovano sotto il vetro, altro materiale di riferimento della storia della laguna veneta... Presentandosi nella loro bellezza individuale mostrano sia il carattere esterno sia quello interno. I molluschi del mare non coprono più la loro superficie ma restano le loro tracce. L'interno della "bricola", legno di quercia, rimasto nascosto, è ancora forte e duro. Nel mio progetto diventa elemento portante dei tavolini VICE e VERSA.

The new life of the "bricola". They were underwater and now they are under glass, another of the materials that remind us of the history of the Lagoon of Venice... They are present in all their individual beauty, showing off their outer and their inner character. Sea-life no longer covers their surface but its traces remain. The inside of the "bricola", oak wood, still hidden, is strong and hard as ever. In my project it remains the load-bearing element of the small tables VICE and VERSA.

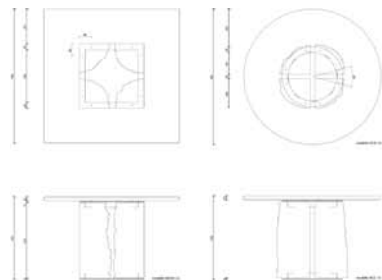

Thomas Herzog



Slice of Briccole Slice of Venice

“Da 25 anni, vivo a Burano. Si è ancora lontani da Venezia, la nebbia rende opaco, minaccioso e infinito il paesaggio della laguna. Da perdersi definitivamente. Ma ci sono le Briccole. Di giorno sono alte e nobili. Di notte, indispensabili. Nella nebbia, sono vitali. Tutto delle Briccole ha una nobile eleganza. Anche, e soprattutto il suo legno che ora, umilmente, concluderà la sua grande carriera da noi, con noi.

“I’ve lived in Burano, these last 25 years. Venice is far away. The fog on the lagoon is thick, menacing, endless. In it you are lost for ever. But the Briccole are there. By day they are noble. At night indispensable. In the fog they are essential. Everything about the Briccole has a noble elegance. Even and above all the wood, which now, humbly, ends its splendid life in our homes, in our hearts.



Philippe Starck



TRA LE BRICCOLE DI VENEZIA

PAGE 17



UNDER THE PLATE
THE TRAMP ALSO
THE (CHINA) OF THE
LOAD OF WOODS
OF 2.3 mm
HIGH





Pinuccio Sciola

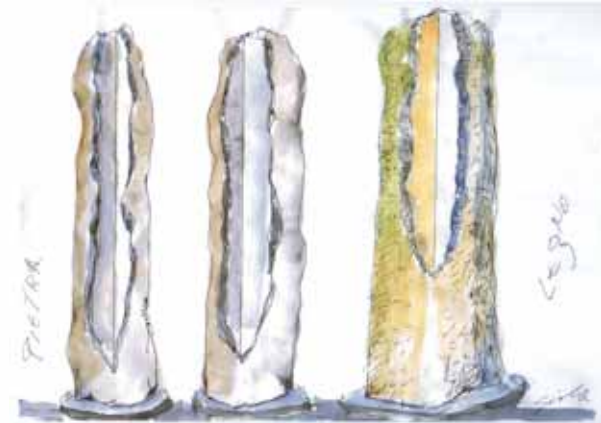

L'anima del legno, l'anima della pietra

Il legno e la pietra.
Due materiali apparentemente senza vita,
ma con una memoria straordinaria
che vive e si manifesta attraverso l'intervento dell'uomo.
L'anima si muove, diventa trasparente, suona,
fa parlare ed emozionare, riprende a vivere con la fantasia,
la manualità e l'amore dell'uomo.

Wood and stone.
Two seemingly lifeless materials,
repositories of an extraordinary memory that comes to life
and reveals itself thanks to the human hand.
Its soul moves, becomes transparent,
resonates with sound, makes us speak
and feel excitement, come to life through the creativity,
the craftsmanship and the love of man.

Unicorno

Quel legno ha una grande storia ed è affascinante volerlo riportare a vita. Nel mio caso volevo ottenere una immagine gentile, capovolgendo la durezza del tronco. L'UNICORNO, declinato in varie forme, è uno sgabello dall'aspetto ironico, come fosse un giocattolo porta fortuna. Un giocattolo di legno, appunto, tagliato in modo primordiale, come fece il falegname Geppetto con Pinocchio. Un giocattolo da adulti, con gli occhi azzurri e rotondi in vetro di Murano, e il corno in bronzo dorato.

That wood carries with it an important story and it is fascinating the idea of trying to bringing it back to life. In my case, I wanted to obtain a gentle image, turning upside down the hardness of the trunk. The UNICORN, conceived in different forms, is an ironic stool, as if it were a good luck toy. A wooden toy, indeed, primordially-cut, as Geppetto did when he created Pinocchio. A toy for adults, with blue and round eyes made of Murano glass, and the horn made of golden bronze.

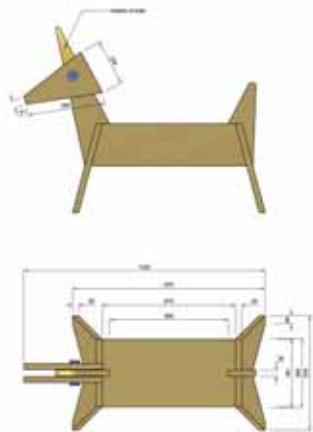

Alessandro Mendini

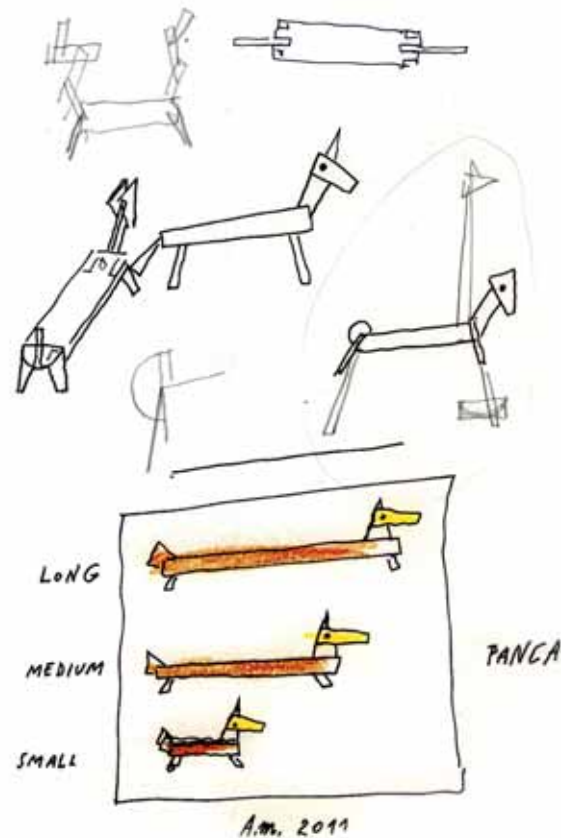

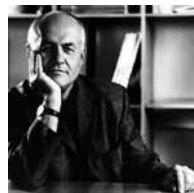

Giuliano Cappelletti

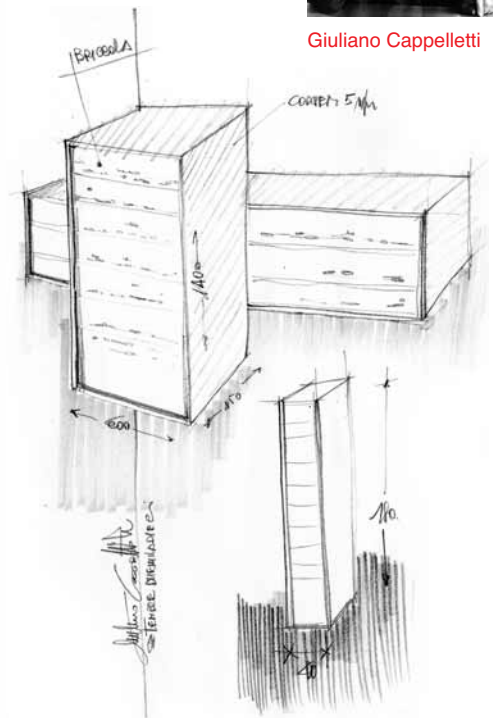

Rialto

Grazie a Maurizio e Davide. Con la loro iniziativa ci hanno dato la possibilità di creare oggetti di vita quotidiana dal recupero dei pali lagunari delle briccole; memoria significativa, pezzi unici e irripetibili. La semplicità delle forme e dei materiali naturali sono elementi distintivi nel design e sono basati sul profondo legame dell'uomo con la natura, la sua armonia ed il suo equilibrio. Ho voluto per questo utilizzare due materiali naturali e diversi che ben si sposano nella ricerca di un ideale equilibrio: il legno delle Briccole e l'acciaio cor-ten. Le briccole subiscono molte variazioni nel corso della loro vita in acqua, si lasciano modellare, consumare e dolcemente accarezzare dal mare della laguna di Venezia e dai suoi abitanti che lasciano tracce visibili della loro presenza in quella che è stata una vita precedente. Il Cor-ten invece si autoprottegge dalla corrosione atmosferica grazie ad una patina superficiale passivante che ne impedisce il progressivo estendersi. Da qui nasce RIALTO, un contenitore che, con la sua struttura sottile, forte e inattaccabile in cor-ten, protegge e incornicia la bellezza della "fragilità" delle briccole veneziane protagoniste indiscusse che lavorate e trasformate danno vita ai volumi dei cassetti del contenitore.

Thank you, Maurizio and Davide. With their initiative they gave us a chance to create common use items out of salvaged materials such as the venetian posts, briccole; significant reminders, unique and one-off works. Simplicity of forms and natural materials are peculiar elements of design, they are based on the deep relationship between nature and man, on its balance and harmony. For this reason I decided to use two natural, though very different, materials that perfectly marry in the search for the ideal balance: briccole wood and cor-ten steel. Briccole are subject to many alterations throughout their lifetime in the water, they are shaped, worn out and smoothly caressed by the sea of the Venetian lagoon and by its inhabitants that leave behind visible traces of their presence. On the other hand, the cor-ten protects itself from atmospheric corrosion thanks to a superficial passive coat that prevents further damage. This is where RIALTO stems from, a container that, thanks to its structure that is thin yet strong, realized in cor-ten, preserves and frames the beauty of briccole's "fragility". Briccole, the unchallenged protagonists of Venice, are here shaped and transformed, giving birth to the solid drawers of the container.



Piero Lissoni

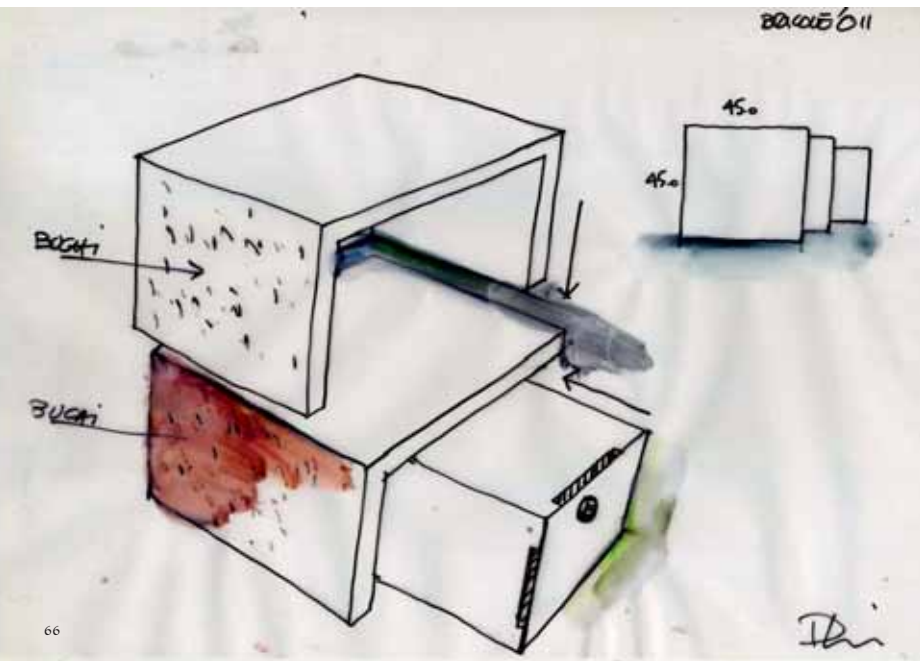
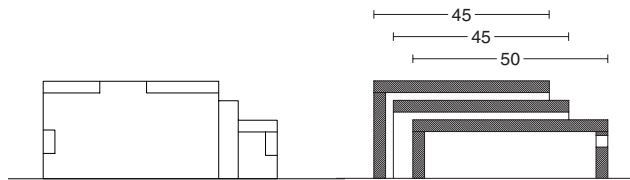

Bric-a-brac

Si tratta di piccoli tavolini da caffè:
ispirati a Venezia, prima importatrice del prodotto.

They are little coffee tables: they take inspiration
from Venice, the very first importer of the product.

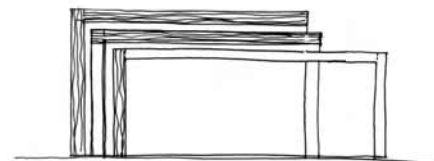

Tavolo

Solo una foglia potrebbe essere più archetipo di un piatto di legno. Questo, poi, legno tosto di briccola, sa anche di mare, di strade marine. Il mio tavolo sale leggero, ha per piede il gambo di un flute, ma il piano è quadrato come la terra. Mi assomiglia molto, in fondo.

Only a leaf could be more archetype than a wooden plate. This especially, the tough briccole wood, tastes of sea and marine streets. My table rises smoothly, with a flute-shaped leg, and a squared top, like earth. After all, it looks like me.

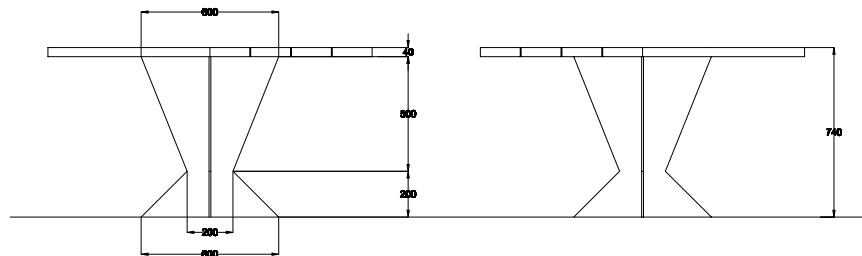
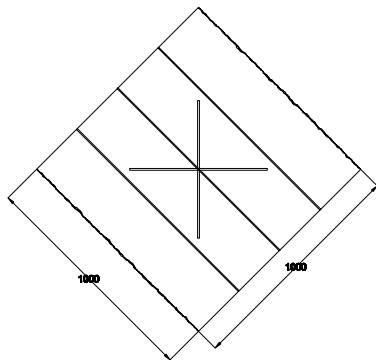

Gualtiero Marchesi





Bricola Venezia

Ricavato dalla forma originale del palo in legno della bricola questo sgabello costituisce l'elemento "base" della Collezione "Briccole di Venezia". Il tronco viene sezionato e levigato nelle due estremità, mentre la superficie verticale è stata volutamente mantenuta così come il mare l'ha modellata. L'altezza dello sgabello Briccola è cm. 44. Il diametro è variabile a seconda delle dimensioni dei pali disponibili. Ogni prodotto viene infine timbrato "a fuoco" con la scritta in dialetto veneziano "bricola Venezia".

In this stool the original shape of the bricola, the wooden Venetian mooring post, has been preserved and this represents the basic element of the "Briccole di Venezia" Collection. The trunk is sectioned and smoothed at the two ends, whereas the vertical surface has been kept on purpose just as the sea had shaped it. The height of the bricola stool is 44 cm. The diameter varies according to the dimensions of the available mooring posts. Finally, each product is "marked" with the words "bricola Venezia" as it would be written in Venetian dialect.



Davide Riva e Maurizio Riva

Tra
le bricole
di
Venezia

1920
R[®]
MADE IN ITALY

In collaborazione con:
In collaboration with:

expoVenezia

 **Fondazione
di Venezia**

Con il patrocinio di
Sponsored by



Si ringrazia
Special thanks to

**ELLE
ZETA**
CONTRACT

